



CPM Crown's **Cascade Aspirators**



HIGH EFFICIENCY SEPARATION



CPM Crown's aspirators are designed to efficiently separate heavy material from lighter material, using a combination of gravity, impact rods, and air.

Product is introduced into the integral feeder, which controls and distributes the feed across the entire cross sectional area of the aspirator, and also provides an air seal. The material free falls through a series of specially designed and positioned impact rods, breaking any bonds between the product and liftings. The heavier phase material is discharged from the bottom of the aspirator, while counter-current air lifts the lighter material. These liftings are lifted to the top of the aspirator, and prior to leaving the unit, are subjected to a final rectification, where any entrained heavy phase material is removed. The standard design includes air inlet and outlet connections for a completely closed loop air system.

Built for **heavy duty** industrial demands



Soybean Processing Applications

Whole Bean Aspirators

These units are built to stand up to the aggressive abrasive nature of whole beans. They are designed to be choke fed or fed by regulated control. An optional variable speed drive system can provide plant flowrate control. The aspirators are typically installed after a scalper or screener. They are primarily designed to remove dust, dirt, and light phase material. The aspirator impact rods are solid steel for long life under extreme service conditions. Heavily built feeders are designed to resist abrasive wear caused by whole beans.

Dehulling Aspirators

Used for aspirating either hot or cold cracked beans, the Crown aspirators will remove the hulls and other loose material from the cracks. Built with the same heavy duty feeder used for whole bean cleaning, the units can either be choke fed or fed by regulated control. The special rectification section removes additional entrained meats from the hulls, reducing the load on the secondary dehulling system. The Crown aspirators are normally designed for closed loop air for warm applications, and are designed to be fully insulated. Depending upon the conditions, a significant amount of drying can be provided. The Crown aspirators can be used for once-through air as well.

Secondary Dehulling

Hull streams from the cleaners, aspirators, and other separation devices contain significant amounts of bean chips and valuable oil. If not recovered, these lost bean chips represent substantial losses in high millfeed residual oil content. Incorporated into a properly designed 2-deck screening system, the secondary aspirator removes the meats from the middle cut. The heavy duty construction provides a long life against abrasion from aggressive hull streams.



The feeder section is built with generous use of abrasion resistant (AR) steel and ceramic lining. The impact rods can be fabricated from a variety of materials, including solid AR steel. Inspection and sample ports are provided as a standard. The Crown Cascade Aspirator is built for long, trouble-free service for even the most demanding applications. Soybean applications include grain cleaning, soybean dehulling, and secondary dehulling. The Crown Aspirators can also be used for many industrial applications.

Integral Feeder for the Most Demanding Applications

The heavy duty feeder is designed to evenly and consistently spread the product across the entire width of the machine. The unit is designed to be choke fed, and when equipped with an optional level control and variable speed drive, provides a completely automatic feeding system.

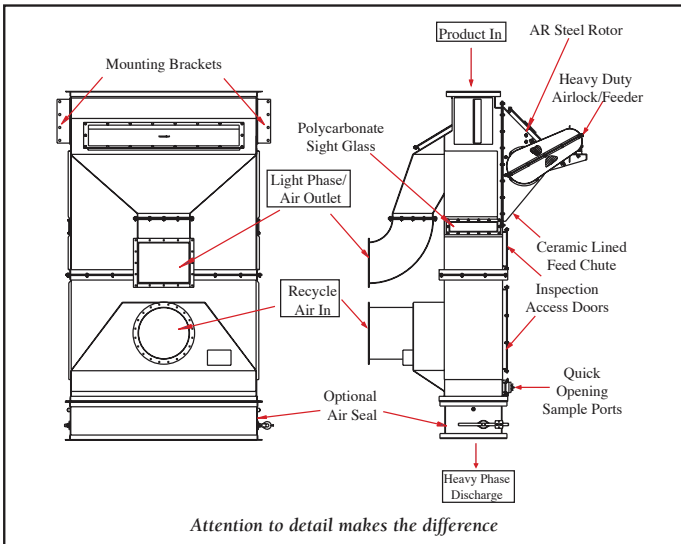
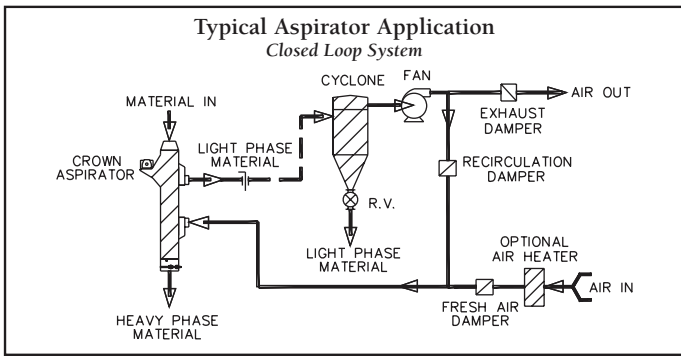

Crown's Cascade Aspirators are available in a variety of sizes for various flow rates and applications. Crown maintains a complete testing facility available for test runs of your product.

Aspirator Sizes Available

MODEL	DEPTH	LENGTH	AIR ACFM
149-000	1' - 3"	1'-0"	700
449-000	1' - 3"	3'-0"	2000
649-000	1' - 3"	4'-0"	2650
949-000	1' - 3"	6'-0"	4000
1049-000	1' - 10"	5'-0"	5800
1249-000	1' - 10"	6'-0"	7000
1849-000	2' - 4"	7'-0"	10,500

For ongoing innovation, Crown's technology and team are second to none.

CPM Crown's Global Innovation Center is a facility unlike any other. A fully functional 15,000 sq. ft. pilot plant, analytical lab and training facility, the GIC offers piloting capabilities from benchtop lab scale to multiple tons per day of continuous production, simulating real life and enabling customers to develop and test new product concepts in a confidential, controlled environment. The GIC has capabilities in preparation, extraction, desolventizing, drying, deodorizing, refining, fat splitting, renewable diesel and specialty extraction (including Hemp CBD Oil). Crown's technical expertise, R&D and full lifecycle process provide guidance and support at every step from feasibility, trials and custom processing to commercial-sized operations and aftermarket.



Feeding, Fueling and Building **a Better World.**



crownsales@cpm.net | +1.651.639.8900 | crowniron.com | OneCPM.com